



**Poliprofile**  
BROACHING TECHNOLOGY

# TECNOLOGÍA DE BROCHADO ROTATORIO

## ROTARY BROACHING TECHNOLOGY





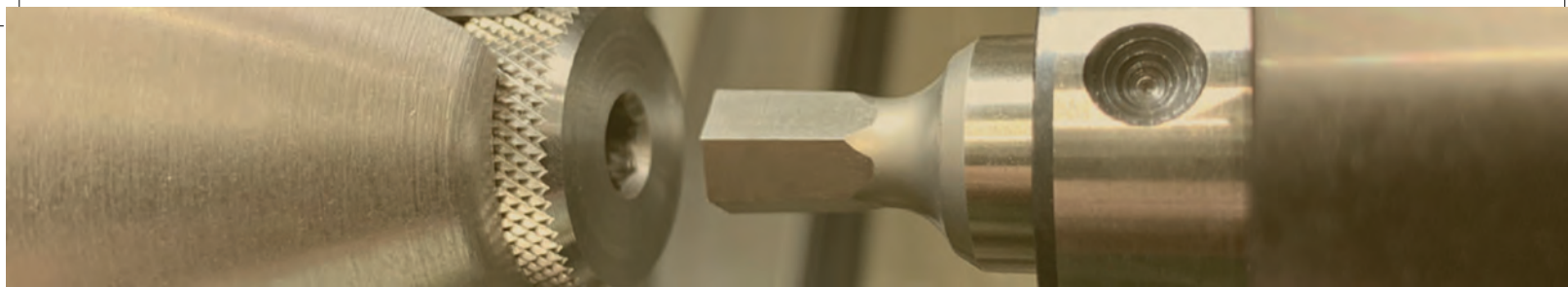

		Página Page
	<b>► Información técnica sobre brochado rotatorio</b> Technical information about rotary broaching	4
	<b>► Cabezales de brochado</b> Rotary broaching heads	
	<ul style="list-style-type: none"> <li>• Mango cilíndrico ..... 14 Cylindrical shank</li> <li>• Mango Weldon ..... 15 Weldon shank</li> <li>• Mango HSK ..... 16 HSK shank</li> <li>• Mango VDI ..... 17 VDI shank</li> <li>• Mango Morse ..... 18 Mose shank</li> <li>• Cabezal regulable ..... 19 Adjustable head</li> </ul>	
	<b>► Punzones / Matrices</b> Broaches / External broaches	
	<ul style="list-style-type: none"> <li>• Punzones hexagonales ..... 20 Hexagonal broaches</li> <li>• Punzones hexagonales en pulgadas ..... 21 Hexagonal broaches in inches</li> <li>• Punzones cuadrados ..... 22 Square broaches</li> <li>• Punzones hexalobulares ..... 23 Hexalobular broaches</li> <li>• Punzones especiales ..... 24 Special broaches</li> <li>• Matrices especiales ..... 25 Special external broaches</li> <li>• Recubrimientos ..... 26 Coatings</li> </ul>	



## BROCHADO ROTATORIO ROTARY BROACHING



### 1. Introducción al brochado rotatorio

El brochado rotatorio es un sistema sencillo, rápido y económico para el mecanizado de formas poligonales (cuadradas, hexagonales, de seis lóbulos, estriadas...) tanto internas, ciegas o pasantes, como externas, en piezas de una amplia gama de materiales.

El principio de funcionamiento es sencillo. El eje de la herramienta de corte (brocha o matriz) tiene una inclinación de  $1^\circ$  con respecto al eje de rotación de la pieza a mecanizar, así como con respecto al eje del mango del cabezal de brochado.

Esta diferencia de ángulo hace que la brocha gire ejecutando un movimiento oscilatorio que provoca un cizallamiento progresivo a medida que se adentra en la pieza.

Este movimiento de cizallamiento reproduce fielmente en la pieza el perfil del elemento de corte utilizado.

Es necesario que la brocha tenga un ángulo de desfilado de  $1,5^\circ$ , para que corte sólo con una pequeña parte de la sección del perfil a brochar.

Si el ángulo es igual o inferior a  $1^\circ$ , la herramienta de corte no cortará correctamente, lo que dará lugar a una mala calidad de las caras cortadas.

Si, por el contrario, el ángulo es superior a  $1,5^\circ$ , aumentamos la fragilidad de la brocha.

Las ventajas del brochado rotatorio son:

- Sistema rápido y preciso
- Reduce el tiempo de mecanizado
- No requiere operaciones secundarias
- Alta calidad de acabado
- Reducción de la fuerza requerida hasta en un 80%
- Preserva la vida de la máquina
- Mecanizado de perfiles en un solo paso

El brochado rotatorio permite en muchos casos la ejecución de formas poligonales trabajando en tornos, centros de mecanizado o incluso taladros, sustituyendo el uso de máquinas de electroerosión o estampación, ahorrando tiempo y dinero.

### 1. Introduction of rotary broaching

Rotary broaching is a simple, fast and economical system for machining polygonal shapes (square, hexagonal, six lobe, splined...) both internal, blind or through, and external, on workpieces made of a wide range of materials.

The operating principle is simple. The axis of the cutting tool (broach or die) has an inclination of  $1^\circ$  from the axis of rotation of the workpiece to be machined, as well as from the axis of the broaching head shank.

This angle difference causes the cutting tool to rotate by executing an oscillatory movement that causes progressive shearing as it goes deeper into the workpiece. This oscillatory movement reproduces faithfully on the workpiece the profile of the cutting tool used.

It is necessary that the cutting tool has  $1.5^\circ$  detachment angle, so that it cuts only with a small part of the profile section to be broached.

If the angle is equal to or less than  $1^\circ$ , the cutting tool will not cut properly, resulting in poor quality of the cut faces. If, on the other hand, the angle is greater than  $1.5^\circ$ , the brittleness of the cutting tool is increased.

The advantages of rotary broaching are:

- Fast and precise system
- Reduces machining time
- No secondary operations required
- High quality finish
- Reduction of force required by up to 80%
- Preserves machine life
- One-step profile machining

Rotary broaching allows in many cases the execution of polygonal shapes working in lathes, machining centers or even drilling machines, replacing the use of EDM machines or stamping, saving time and money.

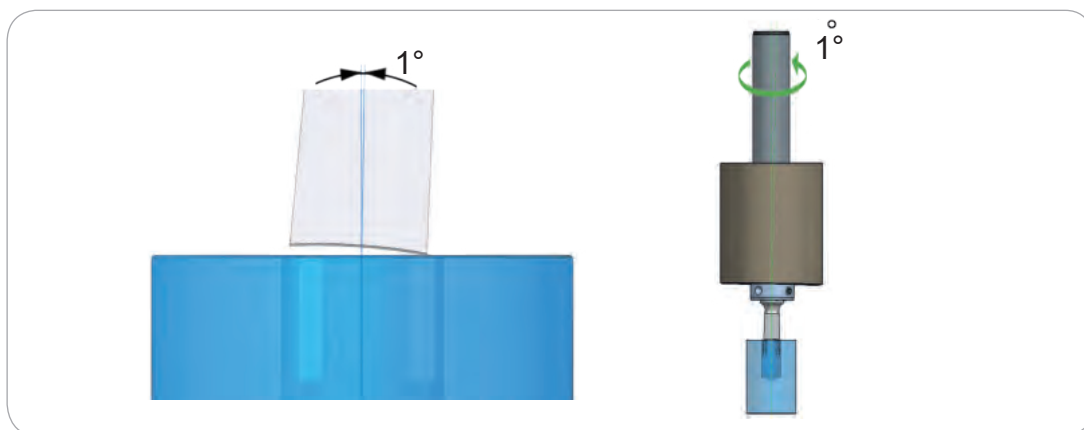

Enclavamiento del punzón  
Broach interlock



## BROCHADO ROTATORIO ROTARY BROACHING



### 2. Brochado en torno o en centro de mecanizado

Los cabezales de brochado tipo "POLIPROFILE" fabricados por INTEGI pueden ser utilizados tanto en tornos como centros de mecanizado y/o taladros.

#### En torno

Cuando se trabaja en un torno (no es necesario tener torreta motorizada), el cabezal de brochado está estático, montado en la torreta del torno, y la pieza gira en el plato del torno.

Cuando la herramienta de corte toca la pieza, empieza a girar junto con la pieza y comienza a realizar el movimiento oscilatorio.

#### En centro de mecanizado y/o taladro

Cuando se trabaja en un centro de mecanizado o en un centro de taladrado, es la pieza la que se sujeta estáticamente en la mesa de la máquina y el cabezal de brochado gira montado en el husillo principal.

Cuando la herramienta de corte toca la pieza, se queda inmóvil, pero el cabezal sigue girando y provoca el movimiento oscilatorio característico de este tipo de herramientas.

### 3. Brochado interior / exterior

Los cabezales de brochado "POLIPROFILE" fabricados por INTEGI pueden utilizarse para el brochado exterior o interior.

La misma cabeza puede utilizarse para ambas aplicaciones.

Para el brochado interior se utiliza una brocha perfilada con la forma a cortar.

Para el brochado exterior es necesario utilizar una matriz de brochado externo con la forma a cortar erosionada y además un soporte para sujetar la matriz al cabezal de brochado.

### 2. Broaching in lathe or machining centre

The "POLIPROFILE" type broaching heads manufactured by INTEGI can be used both on lathes and on machining centers and/or drilling machines.

#### On lathe

When working on a lathe (no necessary to have live tooling turret), the broaching head is static, mounted on the lathe turret, and the workpiece rotates in the lathe chuck.

When the cutting tool touches the workpiece it begins rotating along with the workpiece and starts doing the oscillatory movement.

#### On a machining center and/or drilling center

When working on a machining center or on a drilling center, it is the workpiece that is static clamped on the machine table and the broaching head rotates mounted on the main spindle.

When the cutting tool touches the workpiece, it remains stationary, but the spindle continues rotating and it causes the oscillatory movement characteristic of this type of tools.

### 3. Internal / external broaching

The "POLIPROFILE" broaching heads manufactured by INTEGI can be used for external or internal broaching. The same head can be used for both applications.

For internal broaching a broach profiled with the shape to be cut is used.

For external broaching it is necessary to use an external broaching die with the shape to be cut eroded, and also an adapter to hold the cutting die to the broaching head.

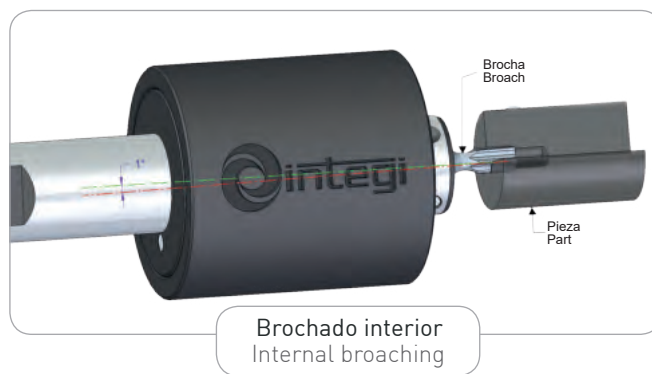
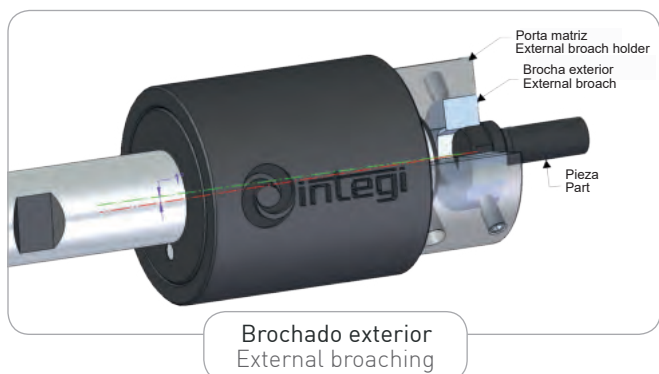



## BROCHADO ROTATORIO ROTARY BROACHING

### 3.1 Preparación de la pieza para el brochado interior

Para el brochado interior es necesario utilizar una brocha con la forma específica que se desea obtener en la pieza.

En el brochado interior se deben tener en cuenta las siguientes recomendaciones:

1. Colocar la brocha en el cabezal de brochado rotativo y asegurarse de que está correctamente centrada, para lo cual será necesaria la ayuda de un reloj comparador.
2. Realice un agujero  $\varnothing D3$  igual o ligeramente mayor que el diámetro mínimo del perfil a brochar.  
En el caso de brochas poligonales (hexagonales, octogonales, cuadradas...) el diámetro  $\varnothing D3$  debe ser igual o mayor que la medida entre caras.
3. El agujero debe ser 1,5 veces más profundo que la longitud total (L) del brochado. Esto es necesario para las virutas.
4. Realice un bisel de  $90^\circ$  en el agujero para facilitar el bloqueo de la brocha al entrar en contacto con la pieza.  
El  $\varnothing D2$  del bisel debe ser igual o mayor que el  $\varnothing D1$  circunscrito del perfil a brochar.
5. La longitud máxima recomendada para el brochado no debe superar 1,5 veces el  $\varnothing D3$  del diámetro interior del perfil a brochar.

### 3.1 Preparing the workpiece for internal broaching

For internal broaching, it is necessary to use a broach with the specific shape to be obtained on the part.

On internal broaching, the following recommendations should be taken into account:

1. Place the broach in the rotary broaching head and make sure it is correctly centered. It will be necessary the help of a dial indicator.
2. Make a bore  $\varnothing D3$  equal or slightly larger than the minimum diameter of the profile to be broached.  
In the case of polygonal broaches (hexagonal, octagonal, square...) the diameter  $\varnothing D3$  must be equal or greater than the dimension between faces.
3. The bore has to be 1.5 times deeper than the (L) total length of the broaching. This is necessary for the chips.
4. Make a  $90^\circ$  bevel to facilitate the broach locking on contact with the workpiece.  
The maximum  $\varnothing D2$  of the bevel must be equal or greater than the circumscribed  $\varnothing D1$  of the shape to be broached.
5. The maximum recommended length to be broached should not exceed 1.5 times the  $\varnothing D3$  inside diameter of the shape to be broached.

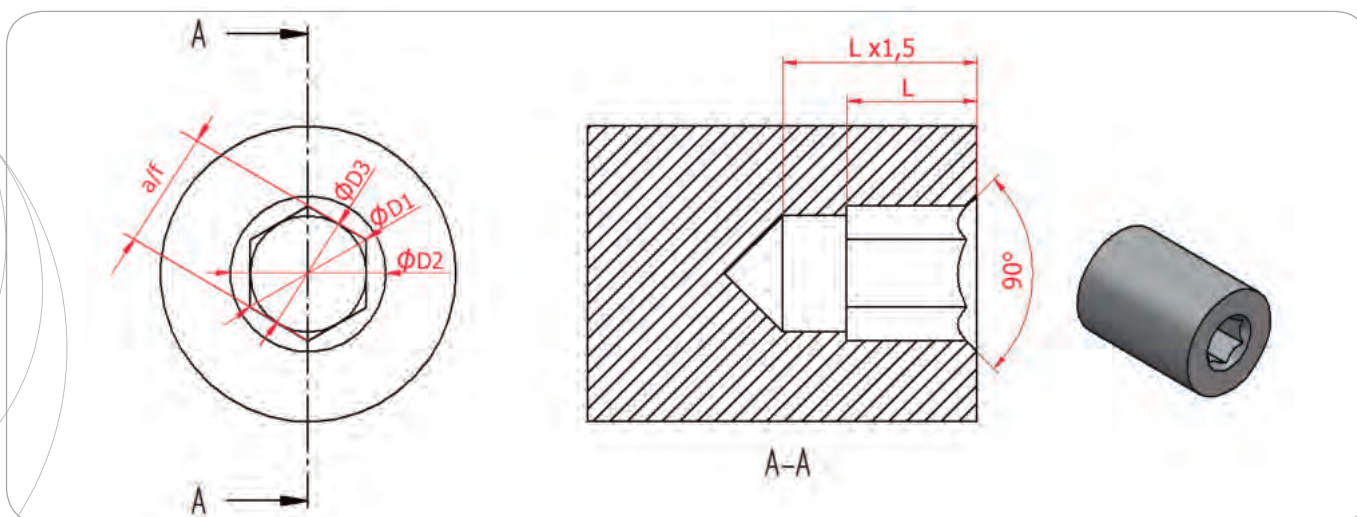



## BROCHADO ROTATORIO ROTARY BROACHING



### 3.2 Preparación de la pieza para el brochado exterior

Para el brochado exterior es necesario utilizar una matriz de brochado exterior, que se monta en un soporte porta matriz.

El conjunto porta-matriz + matriz de brochado se monta a su vez en la parte frontal del cabezal giratorio y se fija mediante espárragos roscados.

Los portamatrices son elementos estándar diseñados específicamente para cada modelo de cabezal de brochado.

A la hora de realizar un brochado exterior, es importante tener en cuenta las siguientes recomendaciones:

1. Colocar el conjunto porta-matriz de brochado+matriz de brochado en el cabezal giratorio y asegurarse de que el conjunto está correctamente centrado, utilizando un reloj comparador.
2. Tornear la pieza a brochar a  $\phi D1$  igual al diámetro circunscrito (máximo) de la figura a brochar.
3. Hacer un chaflán de  $45^\circ$  en la cara frontal de la pieza para facilitar el encaje de la matriz de brochado exterior en la pieza.  
El diámetro mínimo del chaflán  $\phi D2$  debe ser igual o menor que el  $\phi$  inscrito de la figura a brochar  $\phi D3$
4. La longitud máxima de brochado recomendada no puede ser superior a 1,5 veces el diámetro interior del perfil a brochar  $\phi D3$ .
5. No es posible brochar hasta una cara. Al final del brochado se recomienda hacer una ranura de 1,5-2,0 mm de ancho (L1) hasta  $\phi D4$ , que es menor que el diámetro interior de la forma a brochar  $\phi D3$ .  
Esto permitirá que las virutas caigan una vez que la matriz de brochado externa llegue a la ranura.

### 3.2 Part preparation for external broaching

For external broaching it is necessary to use an external broaching die, which is mounted in an external broach holder.

The set broaching die holder + broaching die is fitted to the front of the rotary head and fastened by means of threaded studs.

The die holders are standard elements designed specifically for each broaching head model.

When performing an external broaching, it is important to take into account the following recommendations:

1. Place the set broaching die holder + broaching die in the rotary head and make sure that the set is correctly centered, using a dial indicator.
2. Turn the part to be broached to  $\phi D1$  equal to the circumscribed diameter (maximum) of the figure to be broached.
3. Make a  $45^\circ$  chamfer on the front face of the part to facilitate the engagement of the external broaching die in the part.  
The minimum diameter of the bevel  $\phi D2$  must be equal to or less than the inscribed  $\phi$  of the shape to be broached  $\phi D3$ .
4. The maximum recommended broaching length may not exceed 1.5 times the inside diameter of the profile to be broached  $\phi D3$ .
5. It is not possible to broach up to a face. At the end of broaching it is recommended to make a 1.5-2.0 mm wide groove (L1) up to  $\phi D4$ , which is smaller than the inside diameter of the shape to be broached  $\phi D3$ .  
This will allow the chips to fall out once the external broaching die reaches the groove.

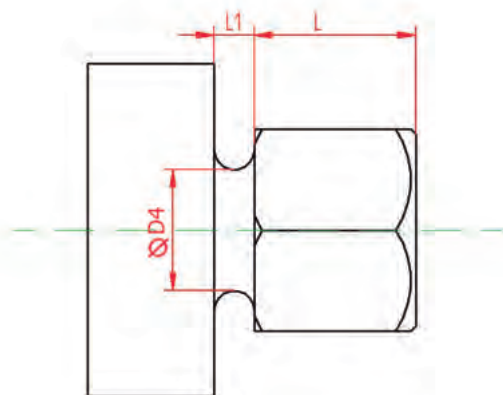
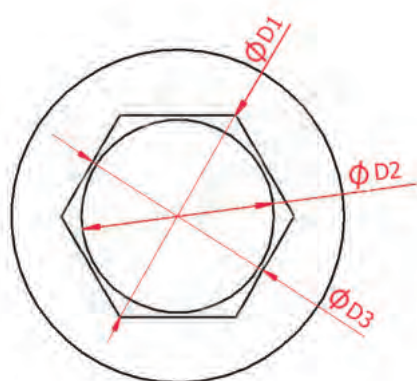



## BROCHADO ROTATORIO ROTARY BROACHING



### 3.3 Portamatriz para brochado exterior

### 3.3 Die holder for external broaching

Código Code	Referencia Reference	Para cabezal For head
060060100	POL1-PTM	POLIPROFILE 1
06060200	POL2-PTM	POLIPROFILE 2
06060300	POL3-PTM	POLIPROFILE 3
06060400	POL4-PTM	POLIPROFILE 4



#### 4. Recomendaciones de rpm y Av.

La velocidad de rotación no es muy importante ya que la brocha gira con la pieza. Sin embargo, comenzar a brochar a altas rpm tiende a tornear la entrada del agujero y puede dañar el borde de la brocha.

La velocidad y el avance dependen de varios factores, como el tamaño de la brocha/matriz, el material de la pieza y el tamaño del pre-taladrado.

Como orientación se recomienda trabajar entre 500-2000 rpm y con un avance entre 0,02- 0,10 mm/vuelta.

Si el avance supera estos valores, la brocha/matriz no corta sino que desgarrar el material, dejando una mala calidad y provocando un desgaste excesivo.

Al principio del brochado es aconsejable reducir la velocidad al máximo hasta que la herramienta (brocha / matriz) quede clavada en el bisel de la pieza y tanto la pieza como la herramienta giren simultáneamente.

Esto evita que la pieza golpee la herramienta a gran velocidad y previene la posible rotura del filo de la herramienta.

También se permite introducir ligeramente la herramienta en la pieza con esta totalmente parada.

Una vez que la pieza y la herramienta giren simultáneamente, aumentar la velocidad de giro hasta los valores recomendados en las tablas.

La herramienta puede retirarse en marcha rápida.

Es imprescindible utilizar una refrigeración abundante en la zona de trabajo aplicada directamente al filo de corte. Este punto es muy importante en el caso del brochado interior.

#### 4. Recommendations of rpm and Av.

Speed is not very important since the broach rotates with the workpiece. However, starting to broach at high rpm tends to turn the bore entrance and may damage the broach edge.

Speed and feed rates depend on several factors, including the broach/die size, the part material and the pre-bore size.

As a guideline it is recommended to work between 500-2000 rpm and with a feed rate between 0.02- 0.10 mm/turn.

If the feed rate exceeds these values, the broach/die does not cut but tears the material, leaving poor quality and causing excessive wear.

At the beginning of broaching it is advisable to reduce the speed as much as possible to ensure that the tool (broach/die) is stuck in the part bevel, and both part and tool rotate simultaneously.

This prevents the workpiece from hitting the tool at high speed and prevents possible breakage of the tool edge.

It is also allowed to lightly driving the broach into the workpiece with the workpiece stopped.

Once the workpiece and tool are rotating simultaneously, increase the rotational speed to the recommended values in tables.

The tool can be removed at rapid traverse.

It is imperative to use abundant cooling on the work zone directly applied to the cutting edge. This point is very important in the case of internal broaching.





## BROCHADO ROTATORIO ROTARY BROACHING



### 5. Velocidad de rotación

Se recomienda trabajar entre 500-2000 rpm.  
La velocidad de giro no tiene mucha relevancia ya que la brocha gira junto con la pieza. Si bien es recomendable trabajar a las revoluciones recomendadas.

### 5. Rotation speed

It is recommended to work between 500-2000 rpm.  
In spite of the fact the speed of rotation is not very important, since the broach rotates together with the workpiece, it is advisable to work at the recommended rpm.

TABLA DE AVANCES / FEEDS TABLE

Material	Avance (mm/vuelta) Feed (mm/rev.)					
	Perfil hexagonal Hexagonal profile		Perfil cuadrado Square profile		Perfil hexalobular Hexalobular profile	
	< 14 mm	> 14 mm	< 12 mm	> 12 mm	< T25	> T27
Acero < 600 N/mm <sup>2</sup> Steel < 600 N/mm <sup>2</sup>	0.10	0.08	0.06	0.04	0.10	0.08
Acero 600 ÷ 800 N/mm <sup>2</sup> Steel 600 ÷ 800 N/mm <sup>2</sup>	0.08	0.06	0.05	0.03	0.08	0.06
Acero 800 ÷ 1200 N/mm <sup>2</sup> Steel 800 ÷ 1200 N/mm <sup>2</sup>	0.06	0.03	0.03	0.02	0.05	0.03
Acero inoxidable < 850 N/mm <sup>2</sup> Stainless steel < 850 N/mm <sup>2</sup>	0.08	0.06	0.04	0.03	0.08	0.06
Acero inoxidable > 850 N/mm <sup>2</sup> Stainless steel > 850 N/mm <sup>2</sup>	0.04	0.03	0.03	0.02	0.04	0.03
Aluminio Aluminium	0.10	0.08	0.08	0.06	0.10	0.08
Bronce Bronze	0.08	0.06	0.07	0.05	0.08	0.06
Titanio no aleado < 700 N/mm <sup>2</sup> Unalloyed titanium < 700 N/mm <sup>2</sup>	0.06	0.03	0.03	0.02	0.05	0.03
Titanio aleado > 700 N/mm <sup>2</sup> Alloyed titanium > 700 N/mm <sup>2</sup>	0.03	0.02	0.02	0.02	0.03	0.02



## BROCHADO ROTATORIO ROTARY BROACHING

### 6. Ajuste de la posición del elemento de corte

Para una correcta ejecución del brochado, con una buena calidad y precisión en la forma de la brocha, es muy importante que la posición del elemento de corte (punzón o matriz) sea la correcta para cada tipo de cabezal de brochado.

La distancia entre la cara frontal de la herramienta (cara de trabajo) y el extremo del cabezal debe ser la indicada en la siguiente tabla:

### 6. Adjustment of the cutting element position

For a correct broaching execution, with a good quality and precision in the broach shape, it is very important that the position of the cutting element (punch or die) is correct for each type of broaching head.

The distance between the front face of the tool (working face) and the end of the head should be as shown in the table below:



Cabezal Broaching head	A
Polipropileno 1	15 mm
Polipropileno 2	15 mm
Polipropileno 3	22 mm
Polipropileno 4	25 mm
Polipropileno - R3	Regulable

**IMPORTANTE / IMPORTANT**



Posición de la matriz. Cota "A"  
External broach position. "A" size



Posición del punzón. Cota "A"  
Internal broach position. "A" size

Si la distancia no es correcta (ya sea más larga o más corta), la herramienta no cortará bien y puede causar problemas de formas inexactas, demasiado empuje en la pieza o puede causar también la generación de una hélice a medida que la herramienta de brochado avanza.

En el caso del brochado interior (trabajo con brocha) el ajuste de su posición se realiza actuando sobre el espárrago roscado situado en el fondo del agujero del porta brocha.

Si la distancia es mayor que la requerida, hay que introducir más el espárrago roscado para acortar la distancia.

Si, por el contrario, la distancia es inferior a la requerida, hay que girar el espárrago roscado en sentido contrario a las agujas del reloj para que salga y se aumente la distancia.

En el caso del brochado exterior, la posición A viene dada por el portamatriz. No hay posibilidad de regulación.

If the distance is not correct (either longer or shorter), the tool will not cut well and may cause problems of inaccurate shapes, too much thrust on the workpiece or may cause also the generation of a helix as the broaching tool progresses.

In the case of internal broaching (working with broach) the adjustment of its position is done by acting on the threaded stud at the bottom of the broach holder bore. If the distance is larger than required, the threaded stud must be inserted further to shorten the distance.

If, on the other hand, the distance is less than required, then the threaded stud must be turned counterclockwise so that it comes out and the distance is increased.

In the case of external broaching, the position A is given by the external broach holder. There is no possibility of adjustment.



## BROCHADO ROTATORIO ROTARY BROACHING



### 7. Brochado con brocha posicionada

El cabezal de brochado POLIPROFILE se suministra con una varilla de posicionamiento, que debe utilizarse únicamente en los siguientes casos:

#### 1. Cuando sea necesario que el perfil brochado esté alineado con alguna parte de la pieza

La brocha gira libremente dentro del cabezal, por lo que no se puede controlar la posición del perfil generado en la pieza si no se utiliza la barra de posicionamiento.

#### 2. Evitar la generación de espirales en caso de brochado profundo

En el brochado interior, cuando el brochado es bastante profundo, la brocha tiende a girar en sentido contrario al de la pieza, generando un brochado en espiral.

Para evitar este problema, es necesario utilizar la varilla como tope para obligar al punzón a girar simultáneamente con la pieza.

#### 3. Brochado hasta el fondo de un agujero ciego

Cuando el brochado debe realizarse hasta el fondo de un agujero ciego y no hay posibilidad de realizar un agujero más profundo para las virutas, es necesario eliminar progresivamente las virutas apiladas delante del punzón.

Para eliminar las virutas, es necesario quitar la brocha y volver a insertar la broca con la que se ha mecanizado el agujero previo. Y después volver a insertar la brocha y así poder seguir brochando.

Pero como la brocha gira libremente, para asegurarse de que en esa segunda vez la brocha volverá a entrar en la misma posición de la primera vez, es necesario utilizar la barra de posicionamiento.

#### 4. Brochado en condiciones extremas

Hay aplicaciones en las que debido a la excesiva sección a cortar, a la excesiva profundidad del brochado o a la dureza del material, el brochado no puede realizarse de una sola vez. En estos casos es necesario repasar el agujero, eliminar las virutas y volver a brochar la profundidad restante.

Para asegurarse de que en esta segunda pasada la brocha vuelva a entrar en la misma posición del primer brochado, es necesario utilizar la barra de posicionamiento.

Además de la varilla de posicionamiento, también es necesario colocar un tope en el plato del torno o en la mesa del centro de mecanizado, de forma que la varilla entre en contacto con el tope justo antes de que la brocha entre en contacto con la pieza, deteniendo así la rotación de la brocha en un punto concreto de la pieza.

### 7. Broaching with broach positioned

The POLIPROFILE broaching head is supplied with a positioning rod, which is to be used only in the following cases:

#### 1. When it is necessary for the broached perfil to be aligned with some part of the workpiece

The broach rotates freely inside the head so the position of the profile generated on the part cannot be controlled if the positioning rod is not used.

#### 2. Avoid the generation of spiralling in case of deep broaching

In internal broaching, when the broaching is quite depth, the broach tends to rotate in the opposite direction to that of the part, generating a spiral broaching.

To avoid this problem, it is necessary to use the rod as a stop to force the punch to rotate simultaneously with the part.

#### 3. Broaching to the bottom of a blind hole

When the broaching is required to be done to the bottom of a blind hole and there is no possibility of making a deeper pre-drilling for the chips, it is necessary to progressively remove the chips piled up in front of the punch.

To remove the chips, it is necessary to take off the broach and reinsert the drill bit with which the previous hole has been machined. And after reinsert the broach and thus be able to continue broaching.

But as the broach rotates freely, to make sure that in that second time the broach will re-enter in the same position of the first time, it is necessary to use the positioning rod.

#### 4. Broaching in extreme conditions

There are applications in which due to the excessive section to be cut, the excessive depth of broaching or the hardness of the material, broaching cannot be done in one go. In these cases it is necessary to rework the hole, remove the chips and then broach the remaining depth again.

To make sure that in this second pass the broach will re-enter in the same position of the first broaching, it is necessary to use the positioning rod.

In addition to the positioning rod, a stop must also be placed on the lathe chuck or machining center table so that the rod contacts the stop just before the broach contacts the workpiece, thus stopping the rotation of the broach at a specific point on the workpiece.

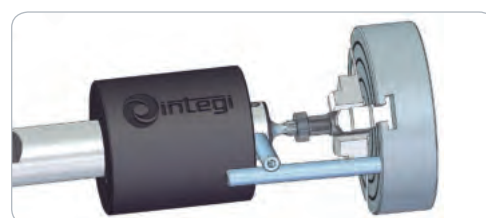



# CABEZALES DE BROCHADO · PUNZONES · MATRICES

## ROTARY BROACHING TOOLS · BROACHES · EXTERNAL BROACHES





## BROCHADO ROTATORIO · CABEZALES ROTARY BROACHING · TOOLS



### MANGO CILÍNDRICO · CYLINDRICAL SHANK

#### + Características

- Utilizable tanto en torno como en centros de mecanizado
- Minimiza el esfuerzo gracias al sistema oscilatorio
- Rodamientos de alta gama que garantizan una larga vida de la herramienta
- Cuerpo estanco para preservar la durabilidad de los rodamientos
- Regulación de la posición del punzón mediante un tope regulable situado en el fondo del portabrochas
- Posibilidad de montar un portamatrix frontal para la realización de brochados externos

#### + Features

- Usable in all types of lathes and machining centers
- Minimizes broach load thanks to the pendular system
- High quality bearings to ensure a long tool life
- Dust-tight body to prevent chips from entering the bearing area
- Adjustment of the position of the broach by an adjustable stop located at the bottom of the broach holder
- Possibility to fit a frontal die-holder for external broaching

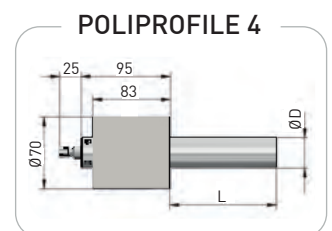
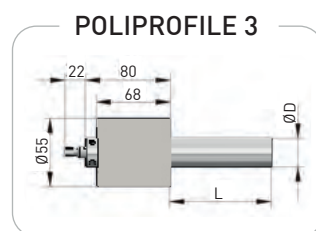
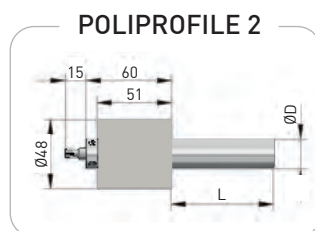
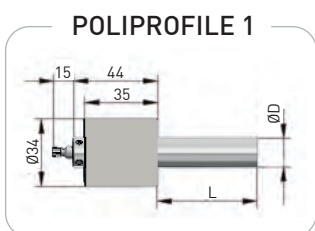

Herramienta   Tool						
Código Code	Referencia Reference	Capacidad Capacity	Punzón Broach	ØD	L	Kg
06010106	Poliprofile1+C10	■<5 ●<6 mm	P-0828-	10 mm	40 mm	0,3
06010104	Poliprofile1+C12	■<5 ●<6 mm	P-0828-	12 mm	40 mm	0,3
06010103	Poliprofile1+C16	■<5 ●<6 mm	P-0828-	16 mm	70 mm	0,4
06010102	Poliprofile1+C3/4"	■<5 ●<6 mm	P-0828-	19.05 mm	70 mm	0,5
06010107	Poliprofile1+C20	■<5 ●<6 mm	P-0828-	20 mm	70 mm	0,5
06010111	Poliprofile1+C22	■<8 ●<10 mm	P-0828-	22 mm	70 mm	0,8
06010203	Poliprofile2+C16	■<8 ●<10 mm	P-0828-	16 mm	70 mm	0,8
06010209	Poliprofile2+C3/4"	■<8 ●<10 mm	P-0828-	19.05 mm	70 mm	1,0
06010204	Poliprofile2+C20	■<8 ●<10 mm	P-0828-	20 mm	70 mm	1,0
06010210	Poliprofile2+C22	■<8 ●<10 mm	P-0828-	22 mm	70 mm	1,2
06010303	Poliprofile3+C16	■<10 ●<14 mm	P-1045-	16 mm	70 mm	1,4
06010310	Poliprofile3+C3/4"	■<10 ●<14 mm	P-1045-	19.05 mm	70 mm	1,4
06010304	Poliprofile3+C20	■<10 ●<14 mm	P-1045-	20 mm	70 mm	1,4
06010325	Poliprofile3+C2040	■<10 ●<14 mm	P-1045-	20 mm	40 mm	1,4
06010312	Poliprofile3+C22	■<10 ●<14 mm	P-1045-	22 mm	70 mm	1,5
06010305	Poliprofile3+C25	■<10 ●<14 mm	P-1045-	25 mm	90 mm	1,4
06010311	Poliprofile3+C1"	■<10 ●<14 mm	P-1045-	25.4 mm	70 mm	1,3
06010410	Poliprofile4+C3/4"	■<16 ●<24 mm	P-1650-	19.05 mm	90 mm	1,3
06010425	Poliprofile4+C20	■<16 ●<24 mm	P-1650-	20 mm	90 mm	1,5
06010403	Poliprofile4+C25	■<16 ●<24 mm	P-1650-	25 mm	90 mm	2,2
06010411	Poliprofile4+C1"	■<16 ●<24 mm	P-1650-	25.4 mm	90 mm	2,2
06010404	Poliprofile4+C32	■<16 ●<24 mm	P-1650-	32 mm	90 mm	2,5
06010405	Poliprofile4+C40	■<16 ●<24 mm	P-1650-	40 mm	90 mm	2,7



## BROCHADO ROTATORIO · CABEZALES ROTARY BROACHING · TOOLS



### WELDON DIN 1835-B

#### + Características

- Utilizable tanto en torno como en centros de mecanizado
- Minimiza el esfuerzo de brochado gracias al sistema oscilatorio
- Rodamientos de alta gama que garantizan una larga vida de la herramienta
- Cuerpo estanco para evitar que las virutas penetren en la zona de los rodamientos
- Regulación de la posición del punzón mediante un tope regulable situado en el fondo del alojamiento del portabrochas
- Posibilidad de montar un portamatrix frontal para la realización de brochados externos

#### + Features

- Usable in all types of lathes and machining centers
- Minimizes broach load thanks to the pendular system
- High quality bearings to ensure a long tool life
- Dust-tight body to prevent chips from entering the bearing area
- Adjustment of the position of the broach by an adjustable stop located at the bottom of the broach holder
- Possibility to fit a frontal die-holder for external broaching

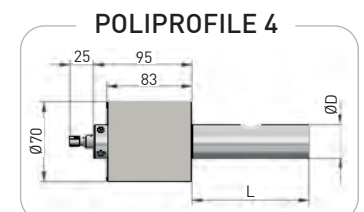
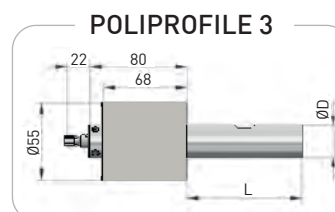
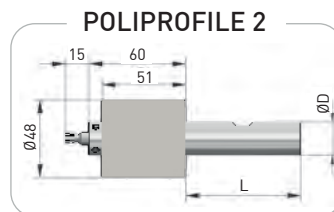
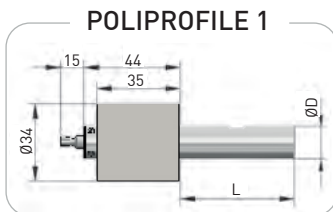

Herramienta   Tool						
Código Code	Referencia Reference	Capacidad Capacity	Punzón Broach	ØD	L	Kg
06010109	POLIPROFILE1+W10	■ <5 ● <6 mm	P-0828-	10 mm	41 mm	0,3
06010108	POLIPROFILE1+W12	■ <5 ● <6 mm	P-0828-	12 mm	46 mm	0,3
06010105	POLIPROFILE1+W16	■ <5 ● <6 mm	P-0828-	16 mm	49 mm	0,4
06010110	POLIPROFILE1+W20	■ <5 ● <6 mm	P-0828-	20 mm	51 mm	0,5
06010205	POLIPROFILE2+W16	■ <8 ● <10 mm	P-0828-	16 mm	52 mm	0,8
06010206	POLIPROFILE2+W20	■ <8 ● <10 mm	P-0828-	20 mm	52 mm	1,0
06010306	POLIPROFILE3+W20	■ <10 ● <14 mm	P-1045-	20 mm	52 mm	1,4
06010307	POLIPROFILE3+W25	■ <10 ● <14 mm	P-1045-	25 mm	59 mm	1,5
06010406	POLIPROFILE4+W25	■ <16 ● <24 mm	P-1650-	25 mm	59 mm	2,2
06010407	POLIPROFILE4+W32	■ <16 ● <24 mm	P-1650-	32 mm	63 mm	2,5



## BROCHADO ROTATORIO · CABEZALES ROTARY BROACHING · TOOLS



### HSK

#### + Características

- Utilizable tanto en tornos como en centros de mecanizado y/o taladros
- Minimiza el esfuerzo gracias al sistema oscilatorio
- Rodamientos de alta gama que garantizan una larga vida de la herramienta
- Cuerpo estanco para preservar la durabilidad de los rodamientos
- Regulación de la posición del punzón mediante un toque regulable situado en el fondo del alojamiento del portabrochas
- Posibilidad de montar un portamatrix frontal para la realización de brochados externos

#### + Features

- Usable in all types of lathes, machining centers, milling machines or drilling machines
- Minimizes broach load thanks to the pendular system
- High quality bearings to ensure a long tool life
- Dust-tight body to prevent chips from entering the bearing area
- Adjustment of the position of the broach by an adjustable stop located at the bottom of the broach holder
- Possibility to fit a frontal die-holder for external broaching

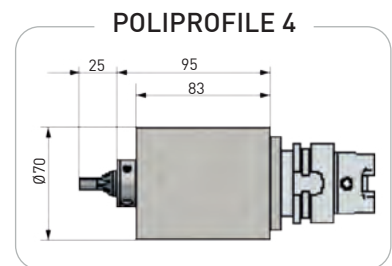
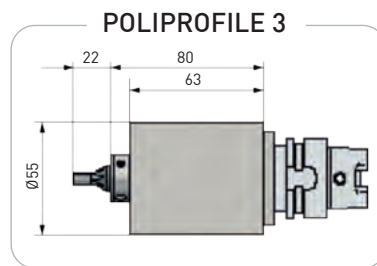
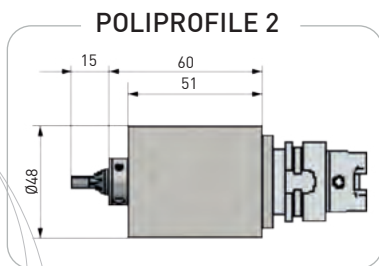

Herramienta   Tool						
Código Code	Referencia Reference	Capacidad Capacity	Punzón Broach	øD	L	Kg
06010211	POLIPROFILE 2+HSK32-A	■ <8    ● <10 mm	P-0828-	10 mm	40 mm	2,6
06010212	POLIPROFILE 2+HSK40-A	■ <8    ● <10 mm	P-0828-	12 mm	40 mm	2,6
06010313	POLIPROFILE 3+HSK50-A	■ <10    ● <14 mm	P-1045-	16 mm	70 mm	2,8
06010412	POLIPROFILE 4+HSK50-A	■ <16    ● <24 mm	P-1650-	19.05 mm	70 mm	2,9
06010413	POLIPROFILE 4+HSK63-A	■ <16    ● <24 mm	P-1650-	20 mm	70 mm	2,9





## BROCHADO ROTATORIO · CABEZALES ROTARY BROACHING · TOOLS



### VDI DIN 69880

#### + Características

- Utilizable tanto en torno como en centros de mecanizado y/o taladros
- Minimiza el esfuerzo de brochado gracias al sistema oscilatorio
- Rodamientos de alta gama que garantizan una larga vida de la herramienta
- Cuerpo estanco para evitar que las virutas penetren en la zona de los rodamientos
- Regulación de la posición del punzón mediante un tope regulable situado en el fondo del alojamiento del portabrochas
- Posibilidad de montar un portamatriz frontal para la realización de brochados externos

#### + Features

- Usable in all types of lathes, machining centers, milling machines or drilling machines
- Minimizes broach load thanks to the pendular system
- High quality bearings to ensure a long tool life
- Dust-tight body to prevent chips from entering the bearing area
- Adjustment of the position of the broach by an adjustable stop located at the bottom of the broach holder
- Possibility to fit a frontal die-holder for external broaching



#### POLIPROFILE 2

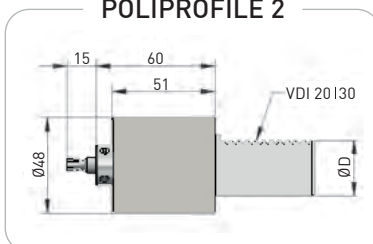

#### POLIPROFILE 3

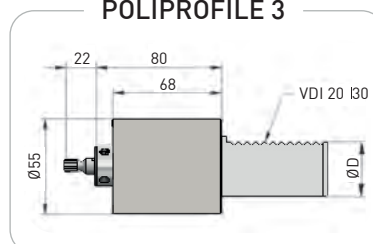

#### POLIPROFILE 4

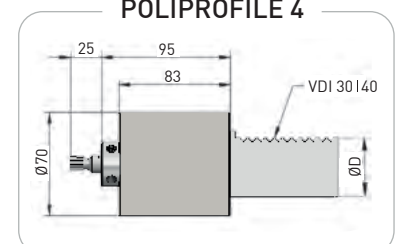

#### Herramienta | Tool

Código Code	Referencia Reference	Capacidad Capacity	Punzón Broach	∅D	Kg
06010207	POLIPROFILE2+VDI20	■ <8 ● <10 mm	P-0828-	20 mm	0,9
06010208	POLIPROFILE2+VDI30	■ <8 ● <10 mm	P-0828-	30 mm	1,0
06010308	POLIPROFILE3+VDI20	■ <10 ● <14 mm	P-1045-	20 mm	1,4
06010309	POLIPROFILE3+VDI30	■ <10 ● <14 mm	P-1045-	30 mm	1,6
06010408	POLIPROFILE4+VDI30	■ <16 ● <24 mm	P-1650-	30 mm	2,1
06010409	POLIPROFILE4+VDI40	■ <16 ● <24 mm	P-1650-	40 mm	2,4



## BROCHADO ROTATORIO · CABEZALES ROTARY BROACHING · TOOLS



### MORSE DIN 228

#### + Características

- Utilizable tanto en torno como en centros de mecanizado y/o taladros
- Minimiza el esfuerzo de brochado gracias al sistema oscilatorio
- Rodamientos de alta gama que garantizan una larga vida de la herramienta
- Cuerpo estanco para evitar que las virutas penetren en la zona de los rodamientos
- Regulación de la posición del punzón mediante un tope regulable situado en el fondo del alojamiento del portabrochas
- Posibilidad de montar un portamatriz frontal para la realización de brochados externos

#### + Features

- Usable in all types of lathes, machining centers, milling machines or drilling machines
- Minimizes broach load thanks to the pendular system
- High quality bearings to ensure a long tool life
- Dust-tight body to prevent chips from entering the bearing area
- Adjustment of the position of the broach by an adjustable stop located at the bottom of the broach holder
- Possibility to fit a frontal die-holder for external broaching

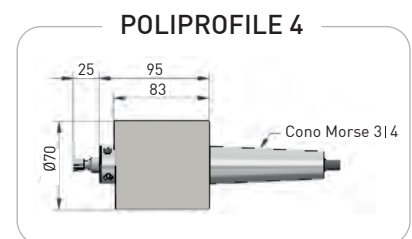
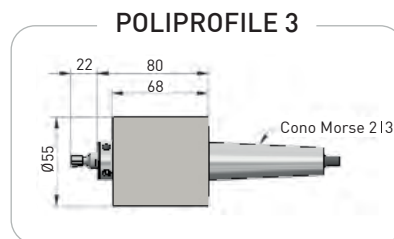
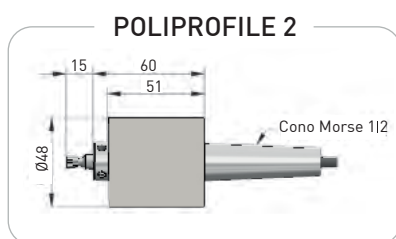

Herramienta   Tool					
Código Code	Referencia Reference	Capacidad Capacity	Punzón Broach	Mango Shank	Kg
06010201	POLIPROFILE2+M1	■ <8   ● <10 mm	P-0828-	MORSE 1	0,9
06010202	POLIPROFILE2+M2	■ <8   ● <10 mm	P-0828-	MORSE 2	1,0
06010301	POLIPROFILE3+M2	■ <10   ● <14 mm	P-1045-	MORSE 2	1,4
06010302	POLIPROFILE3+M3	■ <10   ● <14 mm	P-1045-	MORSE 3	1,6
06010401	POLIPROFILE4+M3	■ <16   ● <24 mm	P-1650-	MORSE 3	2,1
06010402	POLIPROFILE4+M4	■ <16   ● <24 mm	P-1650-	MORSE 4	2,4



## BROCHADO ROTATORIO · CABEZALES ROTARY BROACHING · TOOLS



### POLIPROFILE-R3

#### + Características

- Utilizable tanto en tornos como en centros de mecanizado
- Minimiza el esfuerzo de brochado gracias al sistema oscilatorio
- Rodamientos de alta gama que garantizan una larga vida de la herramienta
- Cuerpo estanco para evitar que las virutas penetren en la zona de los rodamientos
- Posibilidad de montar un portamatriz frontal para la realización de brochados externos
- Sistema de centrado de la brocha para poder realizar brochados situados hasta 65 mm de profundidad

#### + Features

- Usable in all types of lathes or machining centers
- Minimizes broach load thanks to the pendular system
- High quality bearings to ensure a long tool life
- Dust - tight body to prevent chips from entering the bearing area
- Possibility to fit a frontal die-holder for external broaching
- Broach centring system for broaching up to 65 mm deep

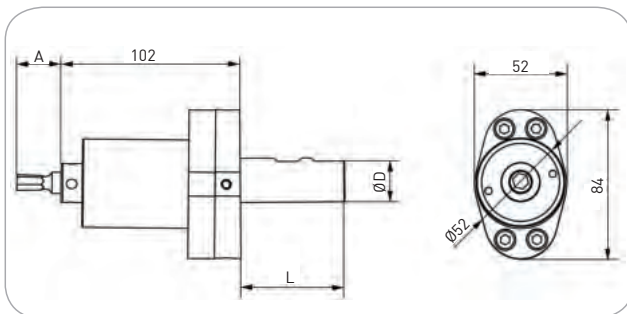

Herramienta | Tool

Código Code	Referencia Reference	ØD (mm)	A (mm)	L (mm)	Punzón Broach	Kg
06010502	POLIPROFILE - R3 + W20	Weldon ø20	25-65	52	P-1255-	1,8
06010503	POLIPROFILE - R3 + W25	Weldon ø25	25-65	59	P-1255-	1,9
06010504	POLIPROFILE - R3 + W32	Weldon ø32	25-65	63	P-255-	2,0

- Aflojar los 4 tornillos (Fig.1)
- Colocando el cabezal sobre su mango, colocar un comparador en el extremo del punzón y girando siempre sobre el mango, verificar el salto de la punta de la brocha (Fig.2)
- Actuando sobre los 4 espárragos "B", ir desplazando ligeramente el cuerpo del cabezal hasta que el salto del punzón quede a +/-0.01 mm (Fig.3)
- Cuando el punzón esté centrado, volver a atar fuertemente los tornillos "A" que bloquean el cuerpo del cabezal.



(Fig.1)

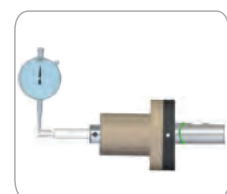

(Fig.2)

- Loosen the 4 screws (Fig.1)
- Place a dial gauge on the end of the broach and, always turning the head on the shank, check the tip of the broach by turning the head on the shank (Fig.2)
- Acting on the 4 studs "B", slightly move the body of the tool until the broach jump is +/-0.01 mm (Fig.3).
- When the broach is centred, re-tighten the screws "A" that lock the body of the tool

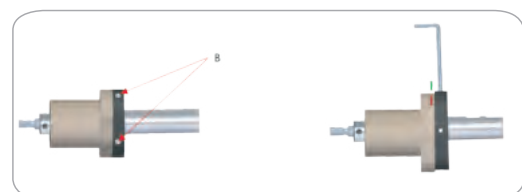

(Fig.3)



# BROCHADO ROTATORIO · PUNZONES

## ROTARY BROACHING · BROACHES



### PUNZONES HEXAGONALES

### HEXAGONAL BROACHES

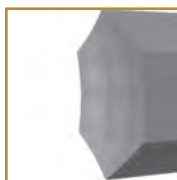

	Código	Referencia	A/F	Tolerancia (mm)	øD	L	Lc
	Code	Reference	(mm)	Tolerance (mm)	(mm)	(mm)	(mm)
POLIPROFILE 1&2	07010101	P-0828-H1.2	1.2	+0,02 / +0,05	ø8	28	1.8
	07010102	P-0828-H1.5	1.5	+0,02 / +0,05	ø8	28	2.3
	07010103	P-0828-H2.0	2	+0,02 / +0,05	ø8	28	3.0
	07010104	P-0828-H2.5	2.5	+0,02 / +0,05	ø8	28	3.8
	07010105	P-0828-H3.0	3	+0,02 / +0,05	ø8	28	4.6
	07010106	P-0828-H4.0	4	+0,02 / +0,05	ø8	28	6.0
	07010107	P-0828-H5.0	5	+0,04 / +0,07	ø8	28	8.6
	07010108	P-0828-H6.0	6	+0,04 / +0,07	ø8	28	9.0
	07010109	P-0828-H7.0	7	+0,04 / +0,07	ø8	28	10.0
	07010110	P-0828-H8.0	8	+0,04 / +0,07	ø8	28	10.8
	07010111	P-0828-H9.0	9	+0,04 / +0,07	ø8	28	13.2
	07010112	P-0828-H10	10	+0,05 / +0,09	ø8	28	11.8

	Código	Referencia	A/F	Tolerancia (mm)	øD	L	Lc
	Code	Reference	(mm)	Tolerance (mm)	(mm)	(mm)	(mm)
POLIPROFILE 3	07020101	P-1045-H1.2	1.2	+0,02 / +0,05	ø10	45	1.8
	07020102	P-1045-H1.5	1.5	+0,02 / +0,05	ø10	45	2.3
	07020103	P-1045-H2.0	2	+0,02 / +0,05	ø10	45	3.0
	07020104	P-1045-H2.5	2.5	+0,02 / +0,05	ø10	45	3.8
	07020105	P-1045-H3.0	3	+0,02 / +0,05	ø10	45	4.6
	07020106	P-1045-H4.0	4	+0,02 / +0,05	ø10	45	6.0
	07020107	P-1045-H5.0	5	+0,04 / +0,07	ø10	45	8.0
	07020108	P-1045-H6.0	6	+0,04 / +0,07	ø10	45	9.0
	07020109	P-1045-H7.0	7	+0,04 / +0,07	ø10	45	10.0
	07020110	P-1045-H8.0	8	+0,04 / +0,07	ø10	45	12.4
	07020111	P-1045-H9.0	9	+0,04 / +0,07	ø10	45	13.4
	07020112	P-1045-H10	10	+0,05 / +0,09	ø10	45	15.0
	07020113	P-1045-H11	11	+0,05 / +0,09	ø10	45	15.4
	07020114	P-1045-H12	12	+0,05 / +0,09	ø10	45	16.4
	07020115	P-1045-H14	14	+0,05 / +0,09	ø10	45	15.6

	Código	Referencia	A/F	Tolerancia (mm)	øD	L	Lc
	Code	Reference	(mm)	Tolerance (mm)	(mm)	(mm)	(mm)
POLIPROFILE 4	07040101	P-1650-H2.5	2.5	+0,02 / +0,05	ø16	50	4.0
	07040102	P-1650-H3.0	3	+0,02 / +0,05	ø16	50	4.6
	07040103	P-1650-H4.0	4	+0,02 / +0,05	ø16	50	6.0
	07040104	P-1650-H5.0	5	+0,04 / +0,07	ø16	50	8.0
	07040105	P-1650-H6.0	6	+0,04 / +0,07	ø16	50	9.4
	07040106	P-1650-H8.0	8	+0,04 / +0,07	ø16	50	13.0
	07040107	P-1650-H10	10	+0,05 / +0,09	ø16	50	15.4
	07040108	P-1650-H12	12	+0,05 / +0,09	ø16	50	17.0
	07040109	P-1650-H14	14	+0,05 / +0,09	ø16	50	18.6
	07040110	P-1650-H16	16	+0,05 / +0,09	ø16	50	19.0
	07040111	P-1650-H17	17	+0,05 / +0,09	ø16	50	22.0
	07040112	P-1650-H18	18	+0,05 / +0,09	ø16	50	22.0
	07040113	P-1650-H19	19	+0,05 / +0,09	ø16	50	19.7
	07040114	P-1650-H22	22	+0,05 / +0,09	ø16	50	20.0
07040115	P-1650-H24	24	+0,05 / +0,09	ø16	50	20.6	

	Código	Referencia	A/F	Tolerancia (mm)	øD	L	Lc
	Code	Reference	(mm)	Tolerance (mm)	(mm)	(mm)	(mm)
POLIPROFILE-R3	07030101	P-1255-H1.5	1.5	+0,02 / +0,05	ø12	55	2.3
	07030102	P-1255-H2.0	2	+0,02 / +0,05	ø12	55	3
	07030103	P-1255-H2.5	2.5	+0,02 / +0,05	ø12	55	3.8
	07030104	P-1255-H3.0	3	+0,02 / +0,05	ø12	55	4.6
	07030105	P-1255-H4.0	4	+0,02 / +0,05	ø12	55	6
	07030106	P-1255-H5.0	5	+0,04 / +0,07	ø12	55	8
	07030107	P-1255-H6.0	6	+0,04 / +0,07	ø12	55	9
	07030108	P-1255-H7.0	7	+0,04 / +0,07	ø12	55	10
	07030109	P-1255-H8.0	8	+0,04 / +0,07	ø12	55	12.4
	07030110	P-1255-H9.0	9	+0,04 / +0,07	ø12	55	13.4
	07030111	P-1255-H10	10	+0,05 / +0,09	ø12	55	15
	07030112	P-1255-H11	11	+0,05 / +0,09	ø12	55	15.4
	07030113	P-1255-H12	12	+0,05 / +0,09	ø12	55	16.4
	07030114	P-1255-H13	13	+0,05 / +0,09	ø12	55	17.4
	07030115	P-1255-H14	14	+0,05 / +0,09	ø12	55	18.6
	07030116	P-1255-H15	15	+0,05 / +0,09	ø12	55	19
	07030117	P-1255-H16	16	+0,05 / +0,09	ø12	55	19



# BROCHADO ROTATORIO · PUNZONES ROTARY BROACHING · BROACHES



## PUNZONES HEXAGONALES EN PULGADAS HEXAGONAL BROACHES IN INCHES

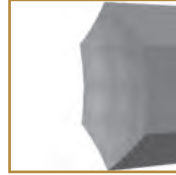

	Código	Referencia	A/F		Tolerancia (mm)	øD	L	Lc
	Code	Reference	Pulgadas	Inches	(mm)	(mm)	(mm)	(mm)
POLIPROFILE 1&2	07010113	P-0828-H1/16"	1/16"	1,59	+0,02/+0,05	ø8	28	3,0
	07010114	P-0828-H5/64"	5/64"	1,98	+0,02/+0,05	ø8	28	3,0
	07010115	P-0828-H3/32"	3/32"	2,38	+0,02/+0,05	ø8	28	3,8
	07010116	P-0828-H7/64"	7/64"	2,78	+0,02/+0,05	ø8	28	4,6
	07010117	P-0828-H1/8"	1/8"	3,18	+0,02/+0,05	ø8	28	6,0
	07010118	P-0828-H9/64"	9/64"	3,57	+0,02/+0,05	ø8	28	6,0
	07010119	P-0828-H5/32"	5/32"	3,97	+0,02/+0,05	ø8	28	6,0
	07010120	P-0828-H11/64"	11/64"	4,37	+0,04/+0,07	ø8	28	8,6
	07010121	P-0828-H3/16"	3/16"	4,76	+0,04/+0,07	ø8	28	8,6
	07010122	P-0828-H7/32"	7/32"	5,56	+0,04/+0,07	ø8	28	9,0
	07010123	P-0828-H1/4"	1/4"	6,35	+0,04/+0,07	ø8	28	10,0

	Código	Referencia	A/F		Tolerancia (mm)	øD	L	Lc
	Code	Reference	Pulgadas	Inches	(mm)	(mm)	(mm)	(mm)
POLIPROFILE 3	07020116	P-1045-H1/16"	1/16"	1,59	+0,02/+0,05	ø10	45	3,0
	07020117	P-1045-H5/64"	5/64"	1,98	+0,02/+0,05	ø10	45	3,0
	07020118	P-1045-H3/32"	3/32"	2,38	+0,02/+0,05	ø10	45	3,8
	07020119	P-1045-H7/64"	7/64"	2,78	+0,02/+0,05	ø10	45	4,6
	07020120	P-1045-H1/8"	1/8"	3,18	+0,02/+0,05	ø10	45	6,0
	07020121	P-1045-H9/64"	9/64"	3,57	+0,02/+0,05	ø10	45	6,0
	07020122	P-1045-H5/32"	5/32"	3,97	+0,02/+0,05	ø10	45	6,0
	07020123	P-1045-H11/64"	11/64"	4,37	+0,04/+0,07	ø10	45	8,6
	07020124	P-1045-H3/16"	3/16"	4,76	+0,04/+0,07	ø10	45	8,6
	07020125	P-1045-H7/32"	7/32"	5,56	+0,04/+0,07	ø10	45	9,0
	07020126	P-1045-H1/4"	1/4"	6,35	+0,04/+0,07	ø10	45	10,0
	07020127	P-1045-H5/16"	5/16"	7,94	+0,04/+0,07	ø10	45	12,4
	07020128	P-1045-H3/8"	3/8"	9,53	+0,04/+0,07	ø10	45	15,0
	07020129	P-1045-H7/16"	7/16"	11,11	+0,04/+0,07	ø10	45	16,4
	07020130	P-1045-H1/2"	1/2"	12,70	+0,05/+0,09	ø10	45	15,6

	Código	Referencia	A/F		Tolerancia (mm)	øD	L	Lc
	Code	Reference	Pulgadas	Inches	(mm)	(mm)	(mm)	(mm)
POLIPROFILE 4	07040116	P-1650-H3/32"	3/32"	2,38	+0,02/+0,05	ø16	50	3,8
	07040117	P-1650-H7/64"	7/64"	2,78	+0,02/+0,05	ø16	50	4,6
	07040118	P-1650-H1/8"	1/8"	3,18	+0,02/+0,05	ø16	50	6,0
	07040119	P-1650-H9/64"	9/64"	3,57	+0,02/+0,05	ø16	50	6,0
	07040120	P-1650-H5/32"	5/32"	3,97	+0,02/+0,05	ø16	50	6,0
	07040121	P-1650-H11/64"	11/64"	4,37	+0,04/+0,07	ø16	50	8,6
	07040122	P-1650-H3/16"	3/16"	4,76	+0,04/+0,07	ø16	50	8,6
	07040123	P-1650-H7/32"	7/32"	5,57	+0,04/+0,07	ø16	50	9,0
	07040124	P-1650-H1/4"	1/4"	6,35	+0,04/+0,07	ø16	50	10,0
	07040125	P-1650-H5/16"	5/16"	7,94	+0,04/+0,07	ø16	50	12,4
	07040126	P-1650-H3/8"	3/8"	9,53	+0,04/+0,07	ø16	50	15,0
	07040127	P-1650-H1/2"	1/2"	12,70	+0,05/+0,09	ø16	50	15,6
	07040128	P-1650-H9/16"	9/16"	14,29	+0,05/+0,09	ø16	50	19,0
	07040129	P-1650-H5/8"	5/8"	15,88	+0,05/+0,09	ø16	50	19,0
	07040130	P-1650-H3/4"	3/4"	19,05	+0,05/+0,09	ø16	50	20,0
07040131	P-1650-H7/8"	7/8"	22,23	+0,05/+0,09	ø16	50	20,06	

	Código	Referencia	A/F		Tolerancia (mm)	øD	L	Lc
	Code	Reference	Pulgadas	Inches	(mm)	(mm)	(mm)	(mm)
POLIPROFILE-R3	07030118	P-1255-H1/16"	1/16"	1,59	+0,02/+0,05	ø12	55	3,0
	07030119	P-1255-H5/64"	5/64"	1,98	+0,02/+0,05	ø12	55	3,0
	07030120	P-1255-H3/32"	3/32"	2,38	+0,02/+0,05	ø12	55	3,8
	07030121	P-1255-H7/64"	7/64"	2,78	+0,02/+0,05	ø12	55	4,6
	07030122	P-1255-H1/8"	1/8"	3,18	+0,02/+0,05	ø12	55	6,0
	07030123	P-1255-H9/64"	9/64"	3,57	+0,02/+0,05	ø12	55	6,0
	07030124	P-1255-H5/32"	5/32"	3,97	+0,02/+0,05	ø12	55	6,0
	07030125	P-1255-H11/64"	11/64"	4,37	+0,04/+0,07	ø12	55	8,6
	07030126	P-1255-H3/16"	3/16"	4,76	+0,04/+0,07	ø12	55	8,6
	07030127	P-1255-H7/32"	7/32"	5,56	+0,04/+0,07	ø12	55	9,0
	07030128	P-1255-H1/4"	1/4"	6,35	+0,04/+0,07	ø12	55	10,0
	07030129	P-1255-H5/16"	5/16"	7,94	+0,04/+0,07	ø12	55	12,4
	07030130	P-1255-H3/8"	3/8"	9,53	+0,04/+0,07	ø12	55	15,0
	07030131	P-1255-H7/16"	7/16"	11,11	+0,05/+0,09	ø12	55	15,6
	07030132	P-1255-H1/2"	1/2"	12,70	+0,05/+0,09	ø12	55	15,6
	07030133	P-1255-H9/16"	9/16"	14,29	+0,05/+0,09	ø12	55	19,0
	07030134	P-1255-H5/8"	5/8"	15,88	+0,05/+0,09	ø12	55	19,0



## BROCHADO ROTATORIO · PUNZONES ROTARY BROACHING · BROACHES



### PUNZONES CUADRADOS SQUARE BROACHES



	Código Code	Referencia Reference	A/F (mm)	Tolerancia (mm) Tolerance (mm)	øD (mm)	L (mm)	Lc (mm)
POLIPROFILE 1&2	07010201	P-0828-C1.2	1.2	+0,02 / +0,05	ø8	28	1.8
	07010202	P-0828-C1.5	1.5	+0,02 / +0,05	ø8	28	2.3
	07010203	P-0828-C2.0	2	+0,02 / +0,05	ø8	28	3
	07010204	P-0828-C3.0	3	+0,02 / +0,05	ø8	28	4.6
	07010205	P-0828-C4.0	4	+0,02 / +0,05	ø8	28	6
	07010206	P-0828-C5.0	5	+0,04 / +0,07	ø8	28	8.6
	07010207	P-0828-C6.0	6	+0,04 / +0,07	ø8	28	9
	07010208	P-0828-C7.0	7	+0,04 / +0,07	ø8	28	10
	07010209	P-0828-C8.0	8	+0,04 / +0,07	ø8	28	10.8

	Código Code	Referencia Reference	A/F (mm)	Tolerancia (mm) Tolerance (mm)	øD (mm)	L (mm)	Lc (mm)
POLIPROFILE 3	07020201	P-1045-C1.2	1.2	+0,02 / +0,05	ø10	45	1.8
	07020202	P-1045-C1.5	1.5	+0,02 / +0,05	ø10	45	2.3
	07020203	P-1045-C2.0	2	+0,02 / +0,05	ø10	45	3
	07020204	P-1045-C2.5	2.5	+0,02 / +0,05	ø10	45	3.8
	07020205	P-1045-C3.0	3	+0,02 / +0,05	ø10	45	4.6
	07020206	P-1045-C4.0	4	+0,02 / +0,05	ø10	45	6
	07020207	P-1045-C5.0	5	+0,04 / +0,07	ø10	45	8
	07020208	P-1045-C6.0	6	+0,04 / +0,07	ø10	45	9
	07020209	P-1045-C7.0	7	+0,04 / +0,07	ø10	45	10
	07020210	P-1045-C8.0	8	+0,04 / +0,07	ø10	45	12.4
	07020211	P-1045-C9.0	9	+0,04 / +0,07	ø10	45	13.4
	07020212	P-1045-C10	10	+0,05 / + 0,09	ø10	45	15

	Código Code	Referencia Reference	A/F (mm)	Tolerancia (mm) Tolerance (mm)	øD (mm)	L (mm)	Lc (mm)
POLIPROFILE 4	07040201	P-1650-C2.5	2.5	+0,02 / +0,05	ø16	50	3.8
	07040202	P-1650-C3.0	3	+0,02 / +0,05	ø16	50	4.6
	07040203	P-1650-C4.0	4	+0,02 / +0,05	ø16	50	6
	07040204	P-1650-C5.0	5	+0,04 / +0,07	ø16	50	8
	07040205	P-1650-C6.0	6	+0,04 / +0,07	ø16	50	9.4
	07040206	P-1650-C8.0	8	+0,04 / +0,07	ø16	50	13
	07040207	P-1650-C10	10	+0,05 / +0,09	ø16	50	15.4
	07040208	P-1650-C12	12	+0,05 / +0,09	ø16	50	17
	07040209	P-1650-C14	14	+0,05 / +0,09	ø16	50	18.6



## BROCHADO ROTATORIO · PUNZONES ROTARY BROACHING · BROACHES



### PUNZONES HEXALOBULARES HEXALOBULAR BROACHES

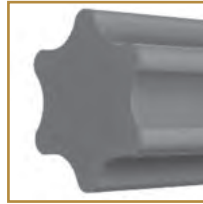

	Código Code	Referencia Reference	E	øD (mm)	L (mm)	Lc (mm)
POLIPROFILE 1&2	06050241	P-0828-PT6	TORX 6	ø8	28	3
	06050242	P-0828-PT8	TORX 8	ø8	28	3.8
	06050243	P-0828-PT10	TORX 10	ø8	28	4.6
	06050244	P-0828-PT15	TORX 15	ø8	28	5.4
	06050245	P-0828-PT20	TORX 20	ø8	28	6.2

	Código Code	Referencia Reference	E	øD (mm)	L (mm)	Lc (mm)
POLIPROFILE 3	06050341	P-1045-PT6	TORX 6	ø10	45	3
	06050342	P-1045-PT8	TORX 8	ø10	45	3.8
	06050343	P-1045-PT10	TORX 10	ø10	45	4.6
	06050344	P-1045-PT15	TORX 15	ø10	45	5.4
	06050345	P-1045-PT20	TORX 20	ø10	45	6.2
	06050346	P-1045-PT25	TORX 25	ø10	45	6.5
	06050347	P-1045-PT30	TORX 30	ø10	45	7
	06050348	P-1045-PT40	TORX 40	ø10	45	8
	06050349	P-1045-PT45	TORX 45	ø10	45	9

	Código Code	Referencia Reference	E	øD (mm)	L (mm)	Lc (mm)
POLIPROFILE 4	06050441	P-1650-PT10	TORX 10	ø16	50	4.6
	06050442	P-1650-PT15	TORX 15	ø16	50	5.4
	06050443	P-1650-PT20	TORX 20	ø16	50	6.2
	06050444	P-1650-PT25	TORX 25	ø16	50	6.5
	06050445	P-1650-PT30	TORX 30	ø16	50	7
	06050446	P-1650-PT40	TORX 40	ø16	50	8
	06050447	P-1650-PT45	TORX 45	ø16	50	9



## BROCHADO ROTATORIO · PUNZONES ROTARY BROACHING · BROACHES



### PUNZONES ESPECIALES SPECIAL INTERNAL BROACHES



En Integi fabricamos todo tipo de punzones especiales para aquellas aplicaciones donde las herramientas estándar no son capaces de dar una solución.

We manufacture all kinds of special broaches for those uses where standard tools cannot be used.

#### Perfil hexagonal

Ø del vástago D \_\_\_\_\_  
Longitud total L \_\_\_\_\_  
Longitud de corte Lc \_\_\_\_\_  
Medida entre caras E \_\_\_\_\_  
Tolerancia de la cota E \_\_\_\_\_  
Recubrimiento \_\_\_\_\_

#### Hexagonal profile

Shank Ø D \_\_\_\_\_  
Overall length L \_\_\_\_\_  
Cutting length Lc \_\_\_\_\_  
Distance across flats E \_\_\_\_\_  
Tolerance of the "E" dimension \_\_\_\_\_  
Coating \_\_\_\_\_

#### Perfil cuadrado

Ø del vástago D \_\_\_\_\_  
Longitud total L \_\_\_\_\_  
Longitud de corte Lc \_\_\_\_\_  
Medida entre caras E \_\_\_\_\_  
Tolerancia de la cota E \_\_\_\_\_  
Recubrimiento \_\_\_\_\_

#### Square profile

Shank Ø D \_\_\_\_\_  
Overall length L \_\_\_\_\_  
Cutting length Lc \_\_\_\_\_  
Distance across flats E \_\_\_\_\_  
Tolerance of the "E" dimension \_\_\_\_\_  
Coating \_\_\_\_\_

#### Perfil estriado

Ø del vástago D \_\_\_\_\_  
Longitud total L \_\_\_\_\_  
Longitud de corte Lc \_\_\_\_\_  
Número de dientes Z \_\_\_\_\_  
Ángulo del vano A1 \_\_\_\_\_  
Ángulo del diente A2 \_\_\_\_\_  
Radio de la cresta R1 \_\_\_\_\_  
Radio del fondo R2 \_\_\_\_\_  
Ø exterior De \_\_\_\_\_  
Ø del fondo Df \_\_\_\_\_  
Recubrimiento \_\_\_\_\_

#### Serration profile

Shank Ø D \_\_\_\_\_  
Overall length L \_\_\_\_\_  
Cutting length Lc \_\_\_\_\_  
Number of teeth Z \_\_\_\_\_  
Hollow angle A1 \_\_\_\_\_  
Tooth angle A2 \_\_\_\_\_  
Crest radius R1 \_\_\_\_\_  
Interior radius R2 \_\_\_\_\_  
Exterior Ø De \_\_\_\_\_  
Interior Ø Df \_\_\_\_\_  
Coating \_\_\_\_\_

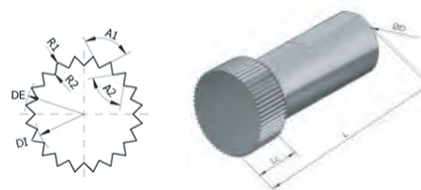
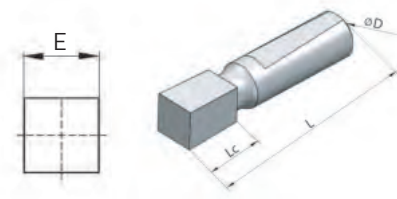
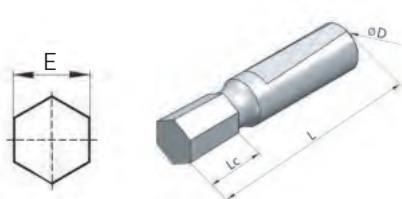

#### Punzones para otros cabezales / Broaches for other rotary broaching heads

Fabricación semi-especial (plazo de entrega reducido) de punzones con geometrías o dimensiones a las estándar de POLIPROFILE aplicables a otras marcas de cabezales de brochado rotatorio.

We also produce "semi-special" broaches (reduced delivery time) with geometries or dimensions different from the standard POLIPROFILE ones, applicable to other brands of rotary broaching heads.







## BROCHADO ROTATORIO ROTARY BROACHING

### MATRICES ESPECIALES SPECIAL EXTERNAL BROACHES

Los cabezales de brochar modelo POLIPROFILE sirven indistintamente para realizar brochados tanto externos como internos. Y en consecuencia también fabricamos brochas o matrices especiales para brochado de ejes.

Si bien mediante el brochado externo se pueden hacer todo tipo de perfiles poligonales (cuadrados, hexagonales, octogonales, dodecagonales...) lo más habitual es que se utilice para el mecanizado de ejes estriados (DIN 5480, DIN 5481, tipo Rosan...)

Las matrices se sujetan en un adaptador o "portamatrix" que amarra al cabezal brochador mediante 3 espárragos roscados.

El portamatrix está diseñado para que la matriz de corte quede firmemente sujeta y a la distancia de corte exacta para cada cabezal brochador.

Para la fabricación de una matriz estriada es necesario un plano de la pieza a brochar con información detallada sobre el perfil.

The POLIPROFILE broaching heads are suitable for internal and external broaching. We also manufacture broaches or special external broaches for shaft broaching.

Although external broaching can be used to make all types of polygonal profiles (square, hexagonal, octagonal, dodecagonal...) it is most commonly used for machining splined shafts (DIN 5480, DIN 5481, Rosan type...)

The dies are clamped in an adapter or "die holder", which is tied to the broaching head by 3 threaded studs.

The die holder is designed to hold the cutting die securely in place and at the exact cutting distance for each broaching head.

For the manufacture of a external spline broach, it is necessary to have a drawing of the part to be broached with detailed information on the profile.

#### Perfil estriado

Matriz para

POLIPROFILE 1  POLIPROFILE 2   
POLIPROFILE 3  POLIPROFILE 4

Ángulo del diente A1 \_\_\_\_\_  
Ángulo del vano A2 \_\_\_\_\_  
Radio de la fondo R1 \_\_\_\_\_  
Radio del cresta R2 \_\_\_\_\_  
Ø del fondo De \_\_\_\_\_  
Ø exterior Df \_\_\_\_\_  
Recubrimiento \_\_\_\_\_

#### Serration profile

External broach for

POLIPROFILE 1  POLIPROFILE 2   
POLIPROFILE 3  POLIPROFILE 4

Tooth angle A1 \_\_\_\_\_  
Hollow angle A2 \_\_\_\_\_  
Interior radius R1 \_\_\_\_\_  
Crest radius R2 \_\_\_\_\_  
Interior Ø De \_\_\_\_\_  
Interior Ø Df \_\_\_\_\_  
Coating \_\_\_\_\_

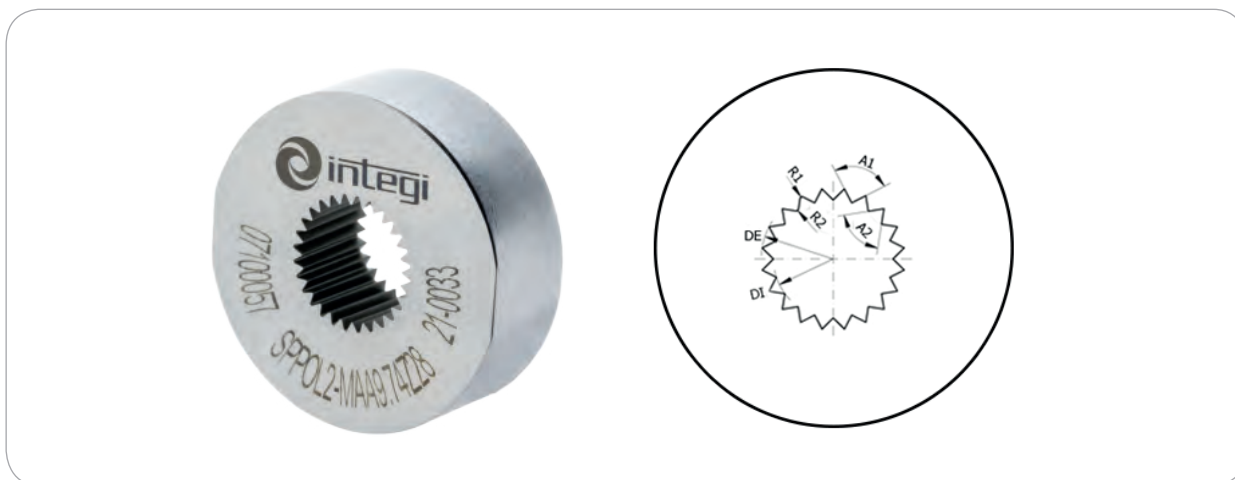



## BROCHADO ROTATORIO · PUNZONES ROTARY BROACHING · BROACHES



### Portamatriz para brochado externo

Hay diferentes tamaños de portamatrices adecuados a cada modelo de cabezal brochador.

### Die holder for external broaching

There are different die holders sizes suitable for each broaching head model.

Código Code	Referencia Reference	Para cabezal For head
060060100	POL1-PTM	POLIPROFILE 1
06060200	POL2-PTM	POLIPROFILE 2
06060300	POL3-PTM	POLIPROFILE 3
06060400	POL4-PTM	POLIPROFILE 4



## RECUBRIMIENTOS COATINGS

Para mejorar el rendimiento de las brochas, INTEGI ofrece diferentes tipos de recubrimientos para:

1. Endurecer la superficie de la brocha y mejorar la resistencia al desgaste.
2. Reducir el coeficiente de fricción de la brocha reduciendo su rugosidad.
3. Mejorar la lubricación de la brocha utilizando recubrimientos autolubricantes.

Los recubrimientos mas usuales en brochado rotatorio son:

#### TIN

Mejora el rendimiento creando una capa antiadehente idónea cuando se trabajan materiales blandos como el aluminio.

#### AlTiN-TiCN

Recomendado para brochar super-aleaciones, aceros abrasivos como el inoxidable o acero fundido.

To improve the performance of the broaches, INTEGI offers different types of coatings for:

1. Harden the surface of the broach improving wear strenght
2. Reduce the coefficient of friction of the broach by reducing its roughness.
3. Improve broach lubrication by using self-lubricating coatings

The most common coatings in rotary broaching are:

#### TIN

Improves performance by creating an anti-adherent surface suitable when working with soft materials such as aluminum.

#### AlTiN-TiCN

Recommended for broaching super-alloys, abrasive steels such as stainless steel, cast iron.

Recubrimiento Coating	Dureza Hardness	Coef. fricc Coefficient of friction	Resistencia abrasión Abrasion resistance	Resistencia adhesión Adhesion resistance
TIN	2400 HV	0,55		
TiCN	3700 HV	0,20		
AlTiN	3800 HV	0,30		





[www.integi.com](http://www.integi.com)



Autonomía, 5  
E-48250 · Zaldibar · Bizkaia · Spain

Tel: +34 943 17 48 00

[integi@integi.com](mailto:integi@integi.com)



Miembro de / Member of:

